

# ELISABETH VON TRAPP STAGE PLOT & LINE INPUT CHART / TWO MUSICIANS

**NOTE:**

Musicians provide their own Direct Boxes  
 Presenter provide XLR cables from DI 's to Stage Box

Lighting Pocket 8 ft Deep 20 ft Wide

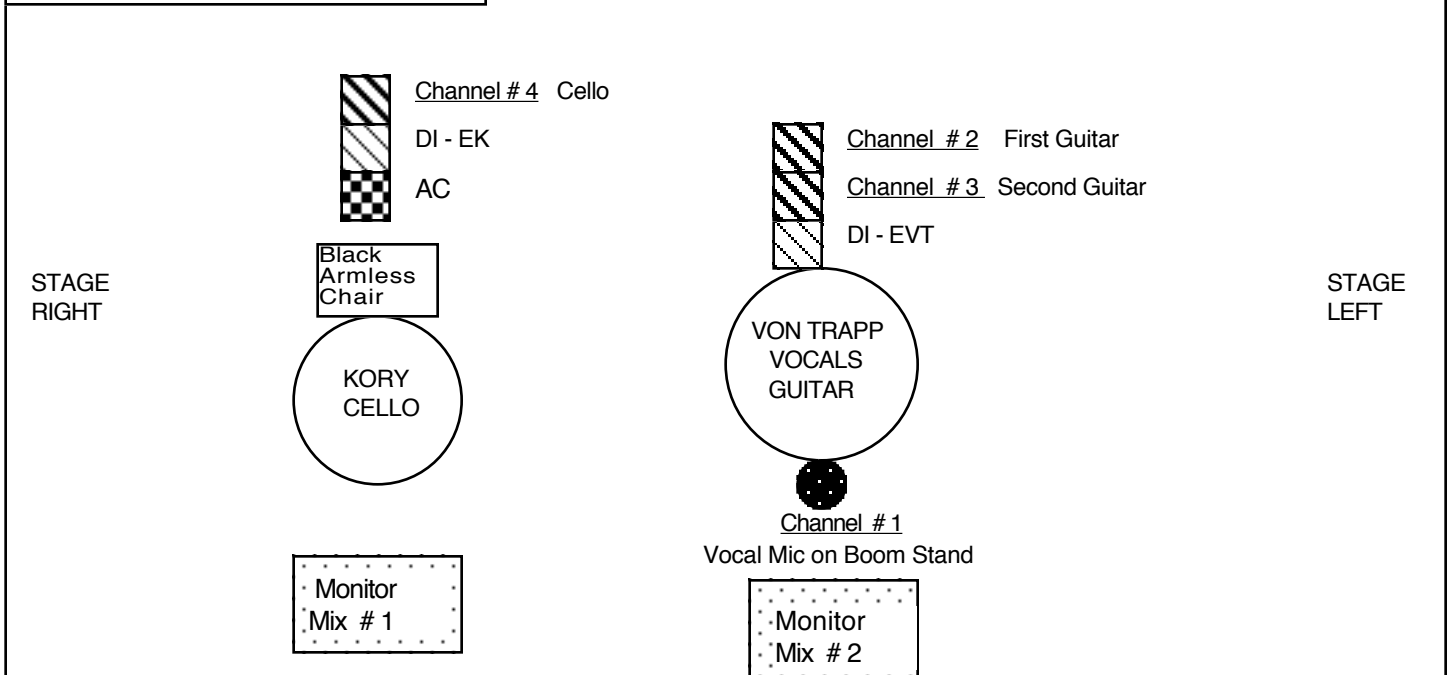

**MUSICIANS PLACEMENT**

Elisabeth von Trapp Standing At Vocal Mic Center Stage  
 Erich Kory Seated Approximately 8 feet Stage Right of Elisabeth

**LINE INPUT**

Channel	Source	Mic
1	EVT Vocal	Shure Beta 58
2	EVT - Guitar # 1	DI -EVT
3	EVT - Guitar # 2	DI -EVT
4	Kory - Cello	DI -EK

**MONITOR MIX**

Monitor Mix # 1 Erich Kory  
 Monitor Mix # 2 Elisabeth von Trapp

**LIGHTING PLACEMENT**

- Place the Musicians within a 12-15 foot wide / 8 foot deep pocket of light
- No lights coming directly from in front of Musicians, They need to see the audience
- Utilize Side Lights, Diagonal Front Lights, top & Back Lights
- Do Not Illuminate Speakers and Wings

AT THE INTERMISSION AND CONCLUSION OF THE CONCERT DO NOT BRING UP THE HOUSE OR STAGE LIGHTS UNTIL ALL MUSICIANS HAVE COMPLETELY LEFT THE STAGE FOR A FULL THREE SECOND COUNT